

Improvement in Power Transmission Capacity by Simultaneous AC-DC Transmission

Bhagyashri G. Sherkhane¹ and M.R. Bachawad²

^{1,2}Department of Electrical Engineering, Government College of Engineering, Aurangabad (M.S.), India.
E-mail: ¹bgsherkhane@gmail.com

Abstract—Now days in power transmission systems mainly the high voltage three phase AC or HVDC transmission lines for greater efficiency at very long distances are used. In this paper, we have to show the scheme of AC and DC power transmission system which can be developed by converting double circuit ac line into composite AC and DC power transmission line and also comparing simulation results with the simple EHVAC transmission system and HVDC transmission system having six pulses PWM generator. The main object of thesis is to show that by superimposing DC in AC transmission, the capacity of the transmission line can be increased by nearly 70 % of that if only AC is transmitted. In our existing transmission system, long extra high voltage (EHV) AC lines cannot be loaded to their thermal limits in order to keep sufficient margin against transient instability. With the scheme proposed in this project, it is possible to load these lines close to their thermal limits. The conductors are allowed to carry usual ac along with dc superimposed on it, without altering the original line conductors, tower structures, and insulator strings has been presented.

Keywords: AC and DC power transmission, flexible AC transmission system (FACTS), MATLAB simulation, six pulses PWM generator, Simultaneous AC-DC transmission.

1. INTRODUCTION

Electric power transmission is nothing but the bulk transfer of electrical energy, from generating power plants to electrical substations which are located near demand center. The transmission lines, when interconnected with each other forms transmission network. To design a transmission networks for transferring the electrical power with high efficiency, some factors are taken into account such as economic factors, network safety and redundancy.

In recent years, the demand of electrical power has uneven growth therefore to transfer such a power for long distance with high efficiency the new transmission line is constructed. The availability of power is generally at remote location which is not close to growing load centers.

These locations are determined by environmental acceptability, regulatory policies and cost of available energy. To transfer a high electric power through existing long AC lines to load centers has certain limitations due to stability considerations. Thus, these lines are not loaded to their

thermal limits to keep sufficient margin against transient stability [1]-[4]. To fulfill the present situation demands the new concepts that allow full utilization of transmission facilities without decreasing system availability and security. The new power electronic technology of flexible AC transmission (FACTS) devices is used in existing AC transmission system to improve stability and achieve power transmission to its thermal limit.

2. LITERATURE SURVEY

In this paper the improvement of power transmission capacity by simultaneous AC-DC transmission is shown. The flexible AC transmission system (FACTS) concepts, based on applying state-of-the-art electronic technology to existing AC transmission system, improve stability and which also gives power transmission close to its thermal limit [1]-[4]. A high voltage direct current (HVDC), electric power transmission system uses direct current for bulk electric power transmission. For long distance transmission the HVDC system has less expensive and having lower electrical losses. In this paper the feasibility study of conversion of double circuit AC line into composite AC-DC line can be done in which DC link having the high voltage DC transmission line which is having certain advantages like environmental, economic, asynchronous connections and power flow control, etc. [5]. The development of DC transmission since in 1950 and which plays a major role in extra-long distance transmission with supplementing EHVAC transmission system. These transmission scheme having the capability to improve the power transferring capacity i.e. power upgrading of a transmission line.

3. SIMULTANEOUS AC-DC POWER TRANSMISSION

3.1 Scheme for Simultaneous Ac-Dc Transmission

Fig. 1 shows the power transmission by using both AC & DC power flow. The simultaneous power flow in AC-DC can be obtained by converting a double circuit AC line into composite AC-DC. This composite AC-DC line carries both

three-phase AC as well as DC power. The each line conductor must carry one third of total DC current along with the AC current flow in the circuit. From the circuit the DC power is obtained through the line commutated 12-pulse Rectifier Bridge & that can be given to the neutral point of sending end zigzag transformers secondary. Again the DC power can be converted into AC by conventional line commutated 12-phase bridge inverter at receiving end zigzag transformers secondary. Here, the inverter bridge is also connected to neutral of receiving end transformer of zigzag connected winding. For the DC current is equally divided among all the three phase of transmission line, the resistance is also maintain equal in all the three phases of secondary winding of zigzag transformer as well as in three conductors of the transmission line.

At the time of DC power flow the transformer may be saturated due to DC current, to avoid the saturation the zigzag connected winding is used at both ends. Also, the three conductors at second line provide the return path for dc current. The harmonics in DC current can be reduced using a high value of reactor 'X_d'. Under normal operating conditions if the absence of zero sequence and third harmonics or it multiple harmonic voltages, the AC current flow through each transmission line can be restricted between the zigzag connected windings & three conductors of the transmission line. Due to high voltage of 'X_d', even the presence of all these components of voltages able to produce negligible current through the ground. The two fluxes produced by the dc current (I_d/3) flowing through each limb of core of zigzag transformer winding are equal in magnitude but opposite in direction. So the net dc flux becomes zero at any instant of time in each limb of the core. Thus, in each limb of core the dc saturation is avoided.

Fig. 2 shows the equivalent circuit of the scheme under normal steady-state operating condition that assumes current control of rectifier and extinction angle control of inverter are constant. The path for AC return current can be denoted by the dotted lines. In the figure, the second transmission line carries return DC current and each line conductor carries (I_d/3) along with AC current per phase. The 'V_{dro}' and 'V_{dio}' are the maximum values of rectifier and inverter side DC voltage respectively and which are equal to $\sqrt{2}$ time's converter AC input line-to-line voltages. The R, L and C are the resistance, inductance and capacitance of the line parameters per phase of each line. The 'α' and 'γ' are the firing and extinction angles of rectifier and inverters, respectively [4], [6]-[8]. Also 'R_{cr}' and 'R_{ci}' are the commutating resistance.

The expressions for AC voltage and current and for active and reactive powers in terms of A,B,C and D parameters of each line can be written by neglecting resistive drops in line conductors and transformer windings due to DC current. Therefore, A, B, C and D parameters of each line may be written as:

$$E_S = AE_R + B \tag{3.1}$$

$$I_S = CE_R + DI_R \tag{3.2}$$

$$P_S + j Q_S = -E_S E_R^* / B^* + [D^* E_S^2 / B^*] \tag{3.3}$$

$$P_R + j Q_R = E_R E_S^* / B^* - [A^* E_R^2 / B^*] \tag{3.4}$$

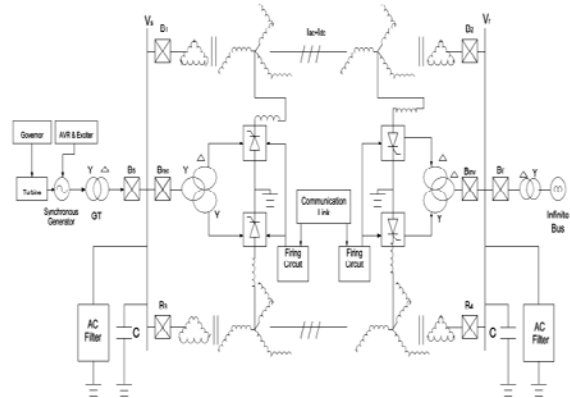

Fig. 3.1: Scheme for composite ac-dc transmission

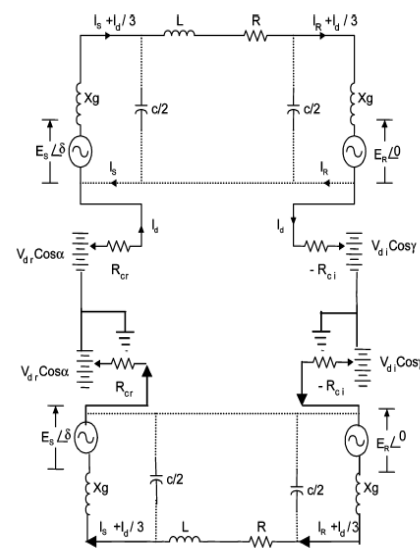

Fig. 3.2: Equivalent Circuit

4. CASE STUDY

4.1 Mathematical Calculations

A synchronous machine is feeding power to infinite bus via a double circuit, with the following specifications. The synchronous machine is dynamically modeled, a field coil on d-axis and a damper coil on q-axis, by Park's equations with the frame of reference based in rotor. It is equipped with an IEEE type AC4A excitation system.

Transmission lines are represented as the Bergeron model. It is based on a Distributed LC parameter travelling wave line

model, with lumped resistance. Its represents the L and C elements of PI section in a distributed manner.

The feasibility of the conversion of the AC Line to Composite AC-DC Line is considered.

Consider data:

Synchronous Machine:

Power = 550 MVA, Voltage = 24KV, Frequency = 50Hz

Transmission line Parameters:

Phase = 3- Φ , Voltage = 400KV, Length (l) =450Km

$$Z=0.03252 + j0.33086 \Omega/\text{Km/ph/ckt} \quad (4.1)$$

$$Y = j0.33797 \times 10^{-6} \text{ S/Km/ph/ckt} \quad (4.2)$$

$$\text{Thermal limit, } I_{th} = 1.8 \text{ KA/ckt} \quad (4.3)$$

$$X = 74.4435 \Omega/\text{ph} \quad (4.4)$$

Sending End Voltage (Rms) = E_s

$$= \frac{400 \text{KV}}{\sqrt{3}} = 230.94 \text{KV} \quad (4.5)$$

Sending End Current, $I_s = \frac{550 \times 10^6}{3 \times 230.94} = 0.793 \text{KA}$

$$\text{Surge impedance, } Z_c = \sqrt{\frac{z}{y}} \quad (4.6)$$

Substituting the Z and Y from equations (4.1) & (4.2) in the equation (4.6), we get

$$Z_c = \sqrt{\frac{0.3324 \angle 84.38}{3.3379 \times 10^{-6} \angle 90}} = 315.29 \angle -2.81$$

$$\gamma l = 450 \times \sqrt{0.3324 \angle 84.38 \times 3.3397 \times 10^{-6}}$$

$$\gamma l = 0.474 \angle 87.14 = 0.023237 + j0.47343 \quad (4.7)$$

4.2 Determination of ABCD Parameters:

A, B, C and D parameters (see appendix-I) of each line are computed as follows:

$$A = \text{Cosh} \gamma l$$

$$= \text{Cosh}(0.023237 + j0.47343)$$

$$= \text{Cosh}(0.023237) \cos(0.47343) + \text{Sinh}(0.023237) \sin(0.47343)$$

$$= 0.999 + j1.918 \times 10^{-4}$$

$$A = 0.999 \angle 0.0109$$

$$B = Z_c \text{Sinh} \gamma l$$

$$= 315.59 \angle -2.81 [\text{Sinh}(0.023237 + j0.47343)]$$

$$= 315.59 \angle -2.81 [\text{Sinh}(0.023237) \cos(0.47343)$$

$$+ j \text{Cosh}(0.023237) \sin(0.47343)]$$

$$B = 7.778 \angle 16.776$$

$$C = \frac{1}{Z_c} \text{Sinh} \gamma l$$

$$= \frac{1}{315.59 \angle -2.81} \text{Sinh}(0.023237 + j0.47343)$$

$$C = 7.804 \times 10^{-5} \angle 22.39$$

We know that. $A = D = 0.999 \angle 0.0109$

Sending end voltage and current are written as:

$$E_s = A.E_r + B.I_r \text{ \& } I_s = C.E_r + D.I_r$$

$$\begin{bmatrix} E_s \\ I_s \end{bmatrix} = \begin{bmatrix} A & B \\ C & D \end{bmatrix} \begin{bmatrix} V_r \\ I_r \end{bmatrix}$$

$$\begin{bmatrix} V_r \\ I_r \end{bmatrix} = \text{Inv} \begin{bmatrix} A & B \\ C & D \end{bmatrix} \begin{bmatrix} E_s \\ I_s \end{bmatrix}$$

$$\begin{bmatrix} E_r \\ I_r \end{bmatrix} = \begin{bmatrix} 0.999 \angle 0.0109 & -7.78 \angle 16.776 \\ -7.804 \times 10^{-5} \angle 22.39 & 0.999 \angle 0.0109 \end{bmatrix} \begin{bmatrix} 230.94 \angle 0 \\ 0.797 \angle 0 \end{bmatrix}$$

$$E_r = 224.764 - j1.749$$

$$I_r = 0.8125 + j8.37$$

$$E_r = 230.94 \angle 0$$

$$I_r = 0.8125 \angle 0.58$$

Therefore the SE and RE Voltage and Currents are calculated:

$$E_s = 230.94 \angle 0 \text{ KV \& } I_s = 0.793 \angle 0 \text{ KA}$$

$$E_r = 224.7 \angle -0.445 \text{ KV \& } I_r = 0.8125 \angle 0.58 \text{ KA}$$

Active and Reactive Power in terms of ABCD parameters are:

$$P_s + jQ_s = \frac{-E_s E_r^*}{B^*} + \frac{D^* E_s^*}{B^*}$$

$$\text{Consider, } \gamma l = \sqrt{yz} = \frac{[230.94 \angle 0 \times 224.77 \angle 0.445 \times 10^6]}{7.778 \angle -16.776}$$

$$+ \frac{0.999 \angle -0.0109 \times (230.94 \angle 0)^2 \times 10^6}{7.778 \angle -16.776}$$

$$= (189.7363 + j3.021) \times 10^6$$

$$P_s + jQ_s = 189.76 \angle 0.91 \text{ M.W}$$

$$P_r + jQ_r = \frac{E_s^* E_r}{B^*} - \frac{A^* E_r^2}{B^*}$$

$$= \frac{[230.94 \angle 0 \times 224.77 \angle 0.445 \times 10^6]}{7.778 \angle -16.776}$$

$$+ \frac{0.999 \angle -0.0109 \times (224.7 \angle 0)^2 \times 10^6}{7.778 \angle -16.776}$$

$$= (-185.2085 + j1.51) \times 10^6$$

$$P_r + jQ_r = 185.209 \angle 179.84 \text{ MW}$$

Therefore the Active and reactive powers of SE & RE are given as:

$$P_s + jQ_s = 189.76 \angle 0.91 \text{ M.W}$$

$$P_R + jQ_R = 185.209 \angle 179.84 \text{ MW}$$

Let,

V_{ph} = per phase rms voltage of original AC line,

V_a = per phase rms voltage of composite AC-DC line,

V_d = DC voltage superimposed on V_{ph}

Allowing maximum permissible voltage offset such that the composite voltage wave just touches zero in every cycle:

$$V_d = V_{ph} / \sqrt{2}$$

Substituting equation (4.5), in the above equation:

$$V_d = 163.299 \text{ KV}$$

And the rms value of voltage of composite AC-DC line is given by_

$$V_a = V_{ph} / 2$$

$$V_a = 115.47 \text{ KV}$$

We know that reactance per phase of double circuit line is $X = 74.4435 \Omega/\text{ph}$. Let δ_1 is the power angle between the voltage at the two ends (to keep sufficient stability margin. δ_1 is generally kept low for long lines and seldom exceeds 30°). And δ_2 is the power angle between the AC voltages at the two ends of the composite line.

Total power transferred through the double circuit line before conversion is as follows:

$$P'_{total} = \frac{3V_{ph}^2 \sin \delta_1}{X}$$

$$I_a = \frac{V \sin \delta / 2}{X}$$

$$P_{total} = P_{ac} + P_{dc} = \frac{3V_a^2 \sin \delta_2}{X} + 2V_d I_d$$

Consider the Power Angle, $\delta_1 = 30^\circ$ & $\delta_2 = 30^\circ$,

Then, $P'_{total} = P_{ac}$,

Substituting equation (4.4) & (4.5),

$$P_{ac} = \frac{3 (230.94)^2 \sin(30)}{74.4435}$$

$$P_{ac} = 1074.6394 \text{ MW}$$

$$\text{AC current/ph/ckt. } I_a = V \frac{\sin 30 / 2}{X}$$

$$= 230.94 \frac{0.5 / 2}{74.4435}$$

$$I_a = 0.7755 \text{ KA}$$

But the dc current, $I_d = \sqrt{I_{th}^2 - I_a^2}$

$$I_d = 3\sqrt{(1.8)^2 - (0.7735)^2}$$

$$I_d = 4.873 \text{ KA}$$

Total power transferred through the composite line is:

$$P_{ac} + P_{dc} = \frac{3 \cdot (115.47)^2 \sin(30)}{74.4435} + 2 \cdot (163.299)(4.873)$$

$$P_{ac+dc} = 1860.16 \text{ MW}$$

4.3 Conclusions

Hence we can conclude from the above equations that, the Power through only the AC circuit is calculated as the $P_{ac} = 1074.6394 \text{ MW}$. When we superimposed the DC current of $I_d = 4.873 \text{ KA}$ over the AC power by maintaining thermal limit, it is observed that the power is improved to the $P_{ac+dc} = 1860.16$. This shows that the load ability of transmission lines are increased by adding DC to the AC in the long transmission lines by maintaining the system stability and thermal limit.

5. SIMULATION MODELS

5.1 Simulink model using HV AC transmission:

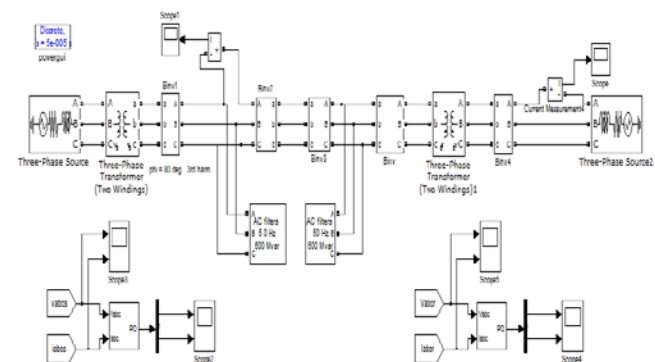

Fig. 5.1 Simulink model using HV AC Transmission

5.2 Simulink model using HV DC transmission:

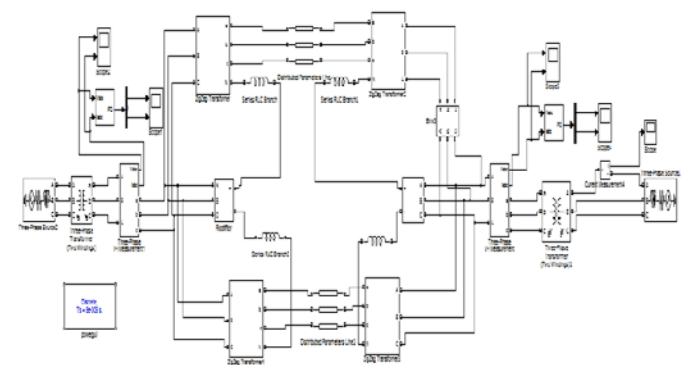

Fig. 5.2: Simulink model using HV DC Transmission

5.3 Simulink model using AC-DC transmission:

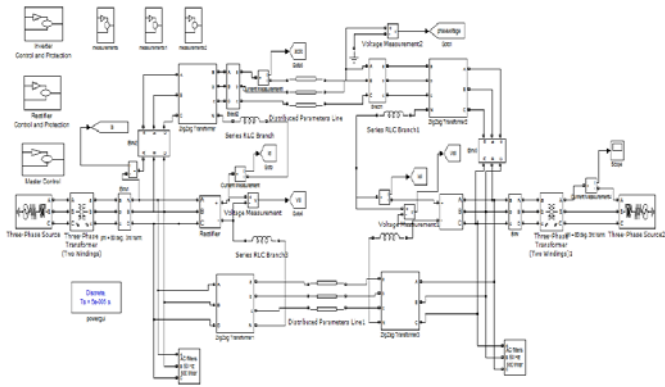

Fig. 5.3: Simulink model using AC-DC Transmission

Active and reactive power at sending end:



6. SIMULATION RESULTS

The performance of the above systems was evaluated with a simulation model using the MATLAB/Simulink.

6.1 Simulation results of HV AC transmission

Voltage and current at sending end:

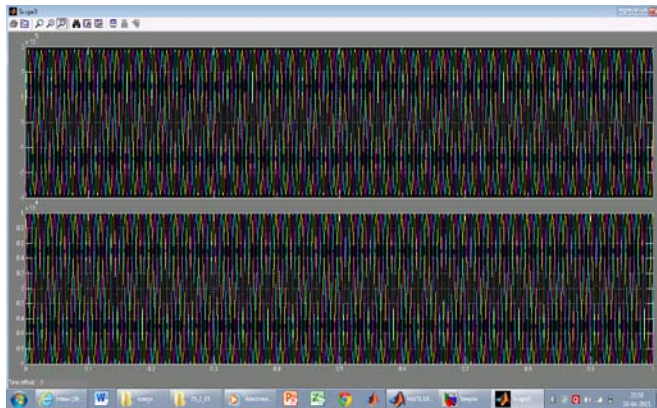

Voltage and current at receiving end:



Active and reactive power at receiving end:

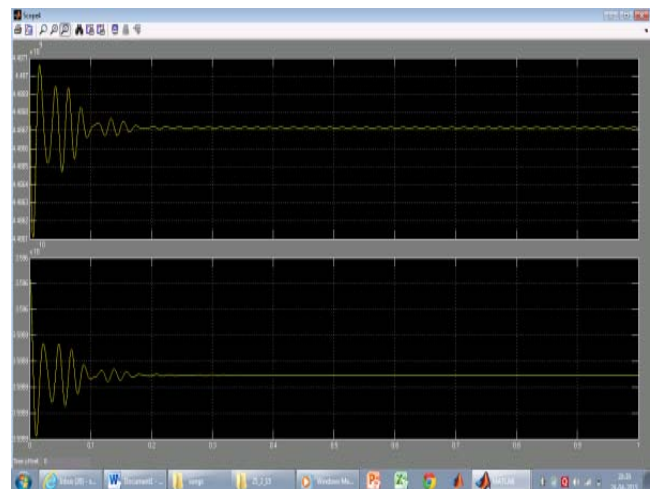

6.2 Simulation results of HVDC transmission:

Voltage and current at sending end:



Voltage and current at receiving end:



6.3 Simulation results of using AC-DC transmission:

Combined AC DC current and AC current in zigzag transformer:

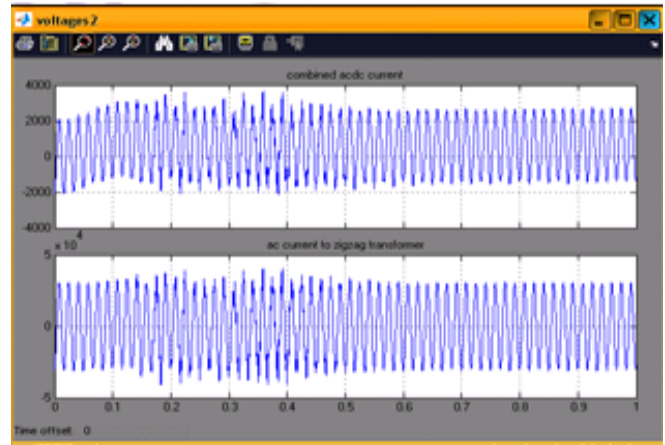

Active and reactive power at sending end:

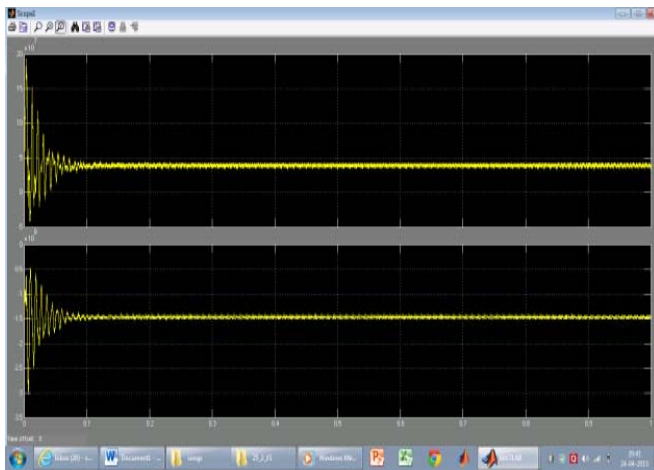

Rectifier AC voltage and current:

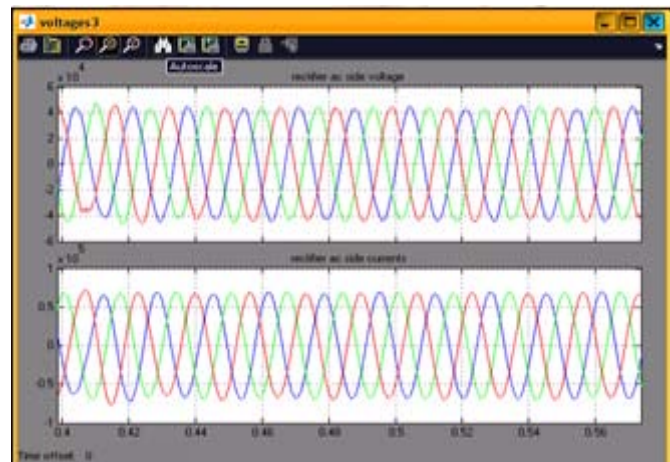

Active and reactive power at receiving end:

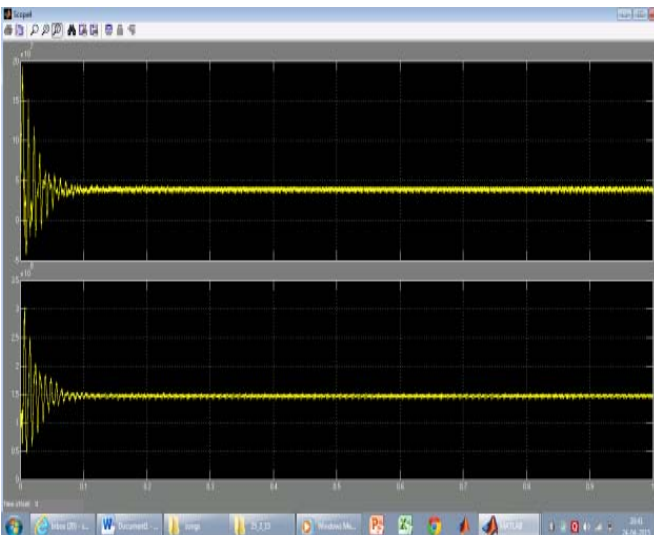

Sending end voltage:

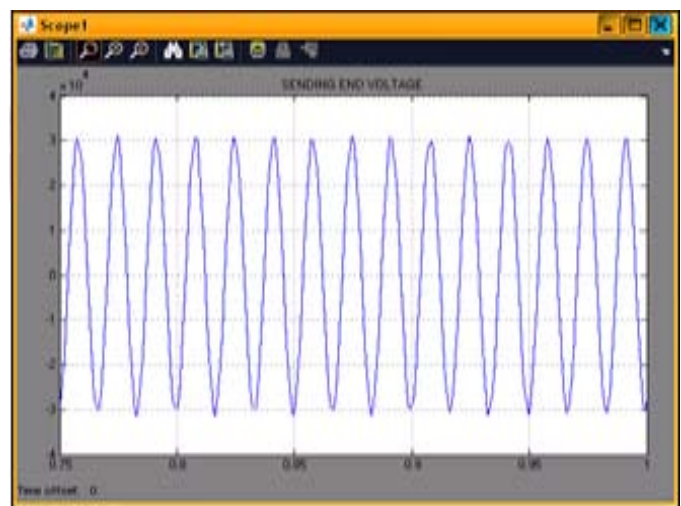

Receiving end voltage:

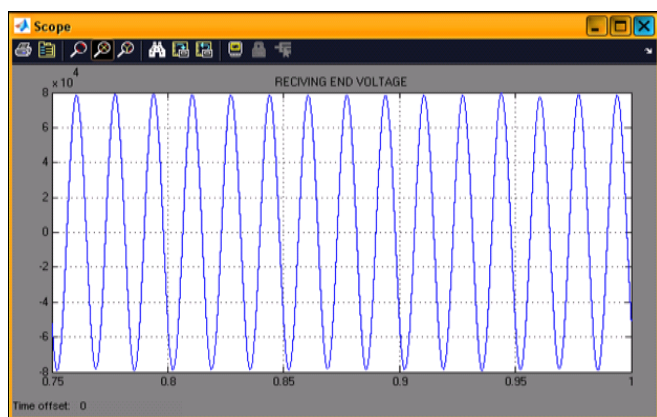

7. CONCLUSION

The power transmission capacity of a transmission line can be improved by using the simultaneous AC-DC transmission system has been demonstrated. This transmission capacity of the transmission line can be increased by nearly 70% of that if AC is transmitted. For the simultaneous AC-DC transmission system studied, which increase the load ability of line up to 83% and also the line loaded to its thermal limit with superimposed DC current. The DC power superimposing in AC transmission does not create in stability problem i.e. does affect the transient stability. In this scheme the DC current regulator modulate the AC power flow without altering the size of conductor, insulator string and tower structure of the original transmission line. The respective Simulink models of HVAC and HVDC transmission systems shows the power transfer ratings which are having the low values than in simultaneous AC-DC transmission system.

8. FUTURE SCOPE

In this paper, it is shown that superimposing the DC in AC transmission improves power transmission capacity of transmission line nearly 70% of only AC transmitted (i.e. by 2 to 4 times) without altering any physical equipment. In every transmission line the faults are occurred which interrupts the power supply, to avoid the faulty conditions some protection schemes are used in transmission line. By considering such a drawback in transmission line and with using a solution

technique this work can be extended for analyzing the faults effect and different protect schemes suitable to that particular type of transmission.

REFERENCES

- [1] L. K. Gyugyi, "Unified power flow concept for flexible A.C. transmission system," Proc. Inst. Elect. Eng., p. 323, Jul. 1992.
- [2] L. K. Gyugyi et al., "The unified power flow controller; a new approach to power transmission control," IEEE Trans. Power Del., vol. 10, no. 2, pp. 1085–1097, Apr. 1995.
- [3] N.G. Hingorani, "FACTS—flexible A.C. transmission system," in Proc. Inst. Elect. Eng. 5th.Int.Conf.A.C.D.C. Power Transmission, London, U.K., 1991.
- [4] P.S. Kundur, "Power System Stability and Control". New York: Mc-Graw-Hill, 1994.
- [5] A. Clerici, L. Paris, and P. Danfors, "HVDC conversion of HVAC line to provide substantial power upgrading," IEEE Trans. Power Del., vol. 6, no. 1, pp. 324–333, Jan. 1991.
- [6] Padiyar, HVDC Power Transmission System. New Delhi, India: Wiley Eastern, 1993.
- [7] E. W. Kimbark, Direct Current Transmission. New York: Wiley, 1971, vol. I.
- [8] J. Arillaga and N. R. Watson, Computer Modelling of Electrical Power Systems. Chichester, U.K.: Wiley, 2003.
- [9] K. P. Basu and B. H. Khan, "Simultaneous ac-dc power transmission," Inst. Eng. (India) J.-EL, vol. 82, pp. 32–35, Jun. 2001.
- [10] H. Rahman and B. H. Khan, "Enhanced power transfer by simultaneous transmission of AC-DC: a new FACTS concept," in Proc. Inst. Elect. Eng. Conf. Power Electronics, Machines, Drives, Edinburgh, U.K., Mar. 31–Apr. 2 2004, vol. 1, pp. 186–191.
- [11] M. A. Chaudhry and D. P. Carroll, "Coordinated active and reactive power modulation of multiterminal HVDC system," IEEE Trans. Power App. Syst., vol. PAS-103, pp. 1480–1485, 1989.
- [12] K. R. Padiyar, M. A. Pai, and C. Radhakrishna, "Analysis of D.C. link control for system stabilization," in Proc. Inst. Elect. Eng. Conf. Publ.No. 205, London, U.K., 1981, pp. 145–148.
- [13] M. Stella, P. K. Dash, and K. P. Basu, "A neuro-sliding mode controller for STATCOM," Elect. Power Compon. Syst., vol. 32, pp. 131–147, Feb. 2004.
- [14] M. Szechtman, T. Wees, and C. V. Thio, "First benchmark model for HVDC control studies," Electra, no. 135, pp. 54–67, Apr. 1991.